

## 1 SAFETY INFORMATION

	<p><b>NEVER ATTACH THIS SPRAY GUN TO EQUIPMENT CAPABLE OF MORE THAN 145 PSI STATIC FLUID PRESSURE!</b></p>
	<p><b>IN THE EVENT OF LEAKAGE, REPLACE GUN IMMEDIATELY!</b></p>
	<p><b>READ THE HELIX LP MAIN UNIT OPERATING MANUAL BEFORE USE!</b></p> <p>Before setting up or using the ProPurge™ low pressure spray gun, read and understand all of the safety instructions in the main operating manual.</p> <ul style="list-style-type: none"> <li>• Follow all material manufacturer's safety warnings.</li> <li>• Always use proper personal protective equipment (PPE) when working with dual component spray chemicals.</li> <li>• Follow all necessary precautions to avoid dangerous spray conditions when spraying in enclosed areas. Ensure sufficient ventilation and eliminate any potential flame/spark sources.</li> <li>• Do not overfill enclosed spaces or build foam beyond the material manufacturer's recommended depth.</li> <li>• Refer to the main unit operating manual for a full list of equipment and chemical warnings.</li> </ul>

## 2 PARTS AND COMPONENTS

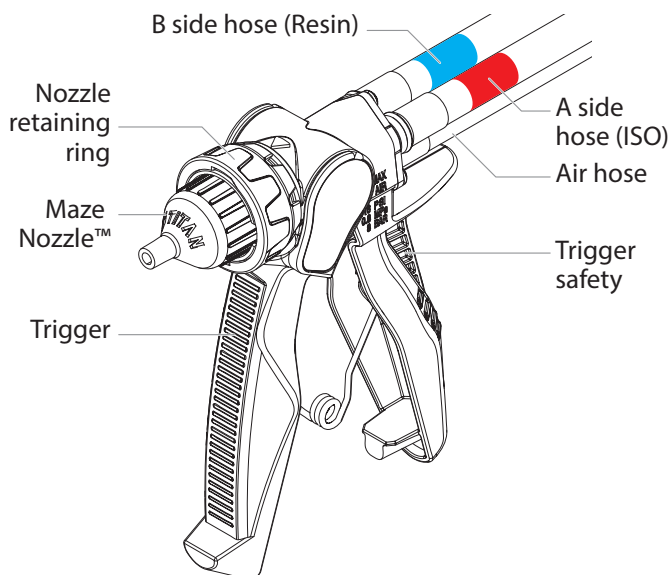

	<p>ProPurge™ LPA gun and Maze Nozzle™ patent pending.</p>
--	---

## 3 SETUP

	<p>Make sure the material ball valves on the Helix LP unit are shut off.</p> <p>Make sure the material ball valves on the whip hoses are in the closed position for removing/attaching the spray gun.</p>
--	---

1. Make sure the material supply hoses as well as the air supply hose are properly connected to the main unit (refer to main unit Operating Manual).
2. Attach the dual heated hose assembly from the main unit to the spray gun.
  - a. Attach the heated A side hose (marked in red) with ball valve to the corresponding A side hose (marked in red) on the spray gun. Tighten with a wrench.
  - b. Attach the heated B side hose (marked in blue) with ball valve to the corresponding B side hose (marked in blue) on the spray gun. Tighten with a wrench.
  - c. Attach the air hose (unmarked) to the corresponding air hose on the spray gun. Tighten with a wrench.

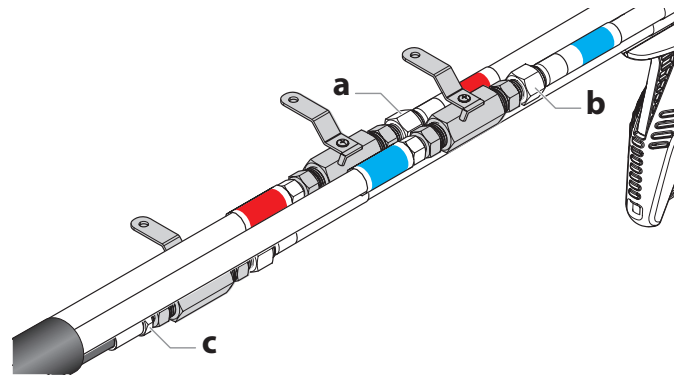

3. Attach the desired Maze Nozzle™.

	<p>A round nozzle (red) will give a round pattern, creating heavier coverage over a smaller area.</p>
--	---

- a. Twist the nozzle retaining ring towards the "unlock" symbol.
- b. Align the tabs on the nozzle with the open slots in the barrel.
- c. Insert the nozzle into the orifice.
- d. Twist the nozzle retaining ring towards the "lock" symbol to secure the nozzle into place.

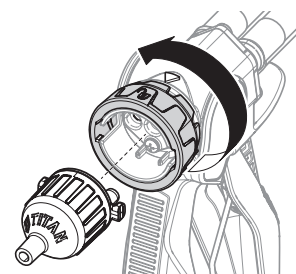



## 4 USAGE



1. Perform the startup procedure on the main unit (refer to the main unit operation manual).
2. Once the system is on and the compressor is running, return to the spray gun and open the air valve. Ensure that air is flowing out of the nozzle.

 <b>Attention</b>	Never trigger the spray gun without air supply on. Doing so will significantly reduce the life of the nozzle and spray gun.
---	---

3. Once the system has achieved the desired pressure and heat settings (refer to the main unit operation manual and material manufacturer's temperature recommendations) the A and B side material inlet valves can now be opened.
4. The system is now ready to spray. The gun will not spray until the trigger and trigger safety are depressed at the same time. This can be achieved by making sure the user's hand is gripping the trigger while at the same time setting the trigger safety within the user's palm.

 <b>Attention</b>	Damage to the spray gun may result when used with an air pressure lower than 30 PSI.
	<p>The spray gun trigger will be locked (it will not spray) as long as the trigger safety is not depressed.</p> <p>It is recommended that the sprayer be tested on a scrap piece of cardboard somewhere outside of the immediate intended spray area.</p>

### 4.1 CHANGING THE NOZZLE

	<p>Nozzle performance is something that can be felt and seen very easily. A new nozzle should produce approximately 300 cycles per minute (CPM) spraying performance.</p> <p>Once the Helix LP is linked and ready to spray, press #4 on the A side control panel. This will display the cycle rate. This range can vary with material and temperature.</p> <p>When the cycle rate drops about 10%, a change in performance should be noticeable, requiring a slower spraying movement. The cycle rate will gradually decrease as the nozzle usage increases.</p> <p>At approximately 100-120 cycles per minute (CPM) applicators may find that spraying movement speed is too slow and replace the nozzle.</p>
	<p>The main unit will automatically manage the pressures and ratio regardless of the cycle rate. It will not be necessary to make any system adjustments.</p> <p>If any leakage is noticeable at the spray gun, immediately stop spraying, close all ball valves on the whip hoses, and replace the spray gun.</p>

## 5 PARTS LIST

Part No.	Description	Gun Qty.	Round Nozzle Qty.
2405674	PROPURGE™ gun and nozzle kit	1	15
0153951	PROPURGE™ gun kit	1	-----
0153952	Round Maze Nozzle™ kit	-----	25
<b>Not included, available for separate purchase (see graphic below):</b>			
0153979	Ball valve		
0138982	Whip hose (blue)		
0138983	Whip hose (red)		

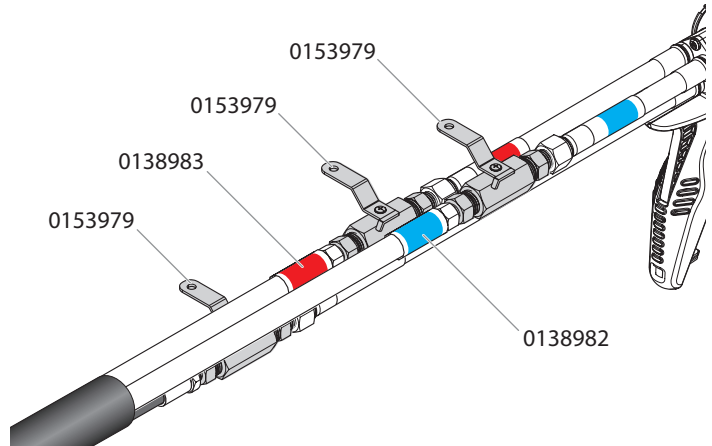

### EU Declaration of conformity

We declare under sole responsibility that this product conforms to the following relevant stipulations:  
2006/42/EC, 2011/65/EU

Applied harmonised norms:  
EN ISO 12100, EN 1953

The EU declaration of conformity is enclosed with the product.  
If required, it can be re-ordered using order number **2399726**.